



**PWT PACKWAY®**

SINCE 1979 PACKAGING SYSTEMS

# PW-553SB+PW-0860A

## AUTO CARTON SEALING MACHINE + FULLY-AUTO STRAPPING MACHINE

PATENT No. 150314

PATENT No. 177724

PATENT No. 182554

**NEW**

### FEATURES:

- This system combines carton sealing machine with auto strapping machine, PW-0860A or PW-0860C, to meet customers' need.
- Providing continuous sealing and strapping offers cost effective and reliable quality, is easy to operate and maintain.
- Carton sealing machine and strapping machine can be used separately.
- All-in-One design for the main head is solid and durable.
- Patent tapping head prevent the OPP being folding and make the carton sealing more smoothly. Furthermore, the machine also installs two or more sets of sensors to meet the strapping needs.
- Its cushiony construction will reduce fraction while sealing cartons.
- 60 seconds auto-stop device will reduce unnecessary consumption and costs.



**APEXPACK®**



ISO 9001 FM57756

**CE**

## FULLY-AUTO STRAPPING MACHINE - steel arch



### OPTIONS :

- If working height is between 730 to 800mm, the casters should be placed outside.
- Detection for strap not feeding to origin or arch properly.  
Detection for non-strap.
- The breaker for electric leakage and safety switch.
- Option for 406 $\phi$  or 280 $\phi$  dispenser.
- Available for PET/PP.

### AVAILABLE ARCH SIZE

H	W	650 (25.6")	850 (33.5")	1050 (41.3")	1250 (49.2")	1450 (57.1")	1650 (65")	1850 (72.8")	2050 (80.7")	2250 (88.6")	2450 (96.5")
400 (15.7")		△	△	△	△	△	△	▲	▲	▲	▲
500 (19.7")		△	△	△	△	△	△	▲	▲	▲	▲
600 (23.6")		△	S	△	△	△	△	▲	▲	▲	▲
800 (31.5")		△	△	△	△	△	▲	▲	▲	▲	▲
1000 (39.4")		▲	▲	▲	▲	▲	▲	▲	▲	▲	▲
1200 (47.2")		▲	▲	▲	▲	▲	▲	▲	▲	▲	▲

S= Standard arch      △= Made on request      ▲= Add on a or up arch motors

PW-0860A

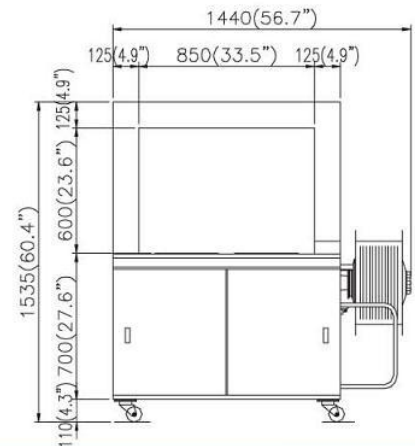
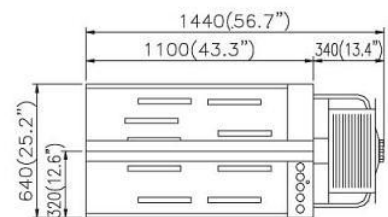

PW-553SB

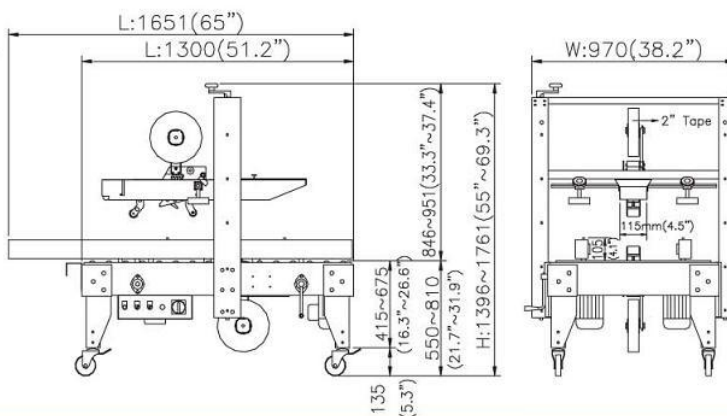

### SPECIFICATIONS :

Model	PW-553SB
Power supply	3 $\phi$ , 220V, 380V, 415V, 440V, (50/60Hz)
Sealing speed	14.2M/per min, 1200cartons/hr (60Hz)
Cartons/hr	7 cartons / min ( 2 straps for L 300mm carton )
Tape width	2" or 3" (2" or 2.5" tape also can be used in 3" tape head with paper roll)
Loading weight	Below 30kgs
Shipping size	L1670 x W1010 x H1400mm ( L66.7" x W39.8" x H55.1" )
Machine size	L1651 x W970 x H1396~1761mm ( L65" x W38.2" x H55"~69.3" )
N.W.	145kgs, 319 (lbs)
G.W.	195kgs, 429 (lbs)

Model	PW-0860A
Power supply	3 $\phi$ , 220V, 380V, 415V, 440V(50/60Hz)
Strape width	9,12,15,19mm
Tension	0~70kgs
speed	2.4 sec. / perstrap
Power consumption	850W
Max. package size	W850 x H600mm (W33.5" x H23.6")
Min. package size	W100 x H30mm (W3.9" x H1.2")
Machine size	L1440 x W640 x H1535mm ( L56.7" x W25.2" x H60.4" )
Shipping size	L1480 x W700 x H1700mm ( L58.3" x W27.6" x H66.9" )
N.W.	220kgs, 484 (lbs)
G.W.	270kgs, 594 (lbs)

Distributor:

Note: Specifications subject to change without notice.